



KASHINOKI SOGYO CO., LTD

製品名

文字高14.2mm赤セグメント5165Rカソードコモン

APPEARANCE			TECHNOLOGY	GaAlAs/GaAs
FACE	SEGMENT	FLAT PIN	SOURCE COLOR	Hi-red
Gray	White	0.30x10.28	DRIVER MODE	Com. Cathode
			PACKING	TUBE(5165)

PACKAGE DIMENSIONS

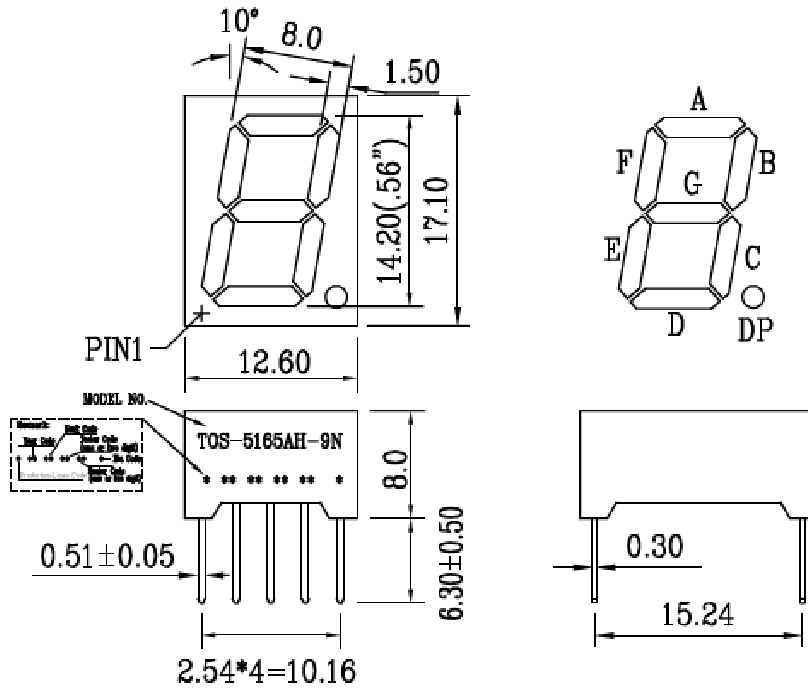

NORMAL TOLERANCE:±0.25 ANGLE:±1°

INTERNAL CIRCUIT DIAGRAM

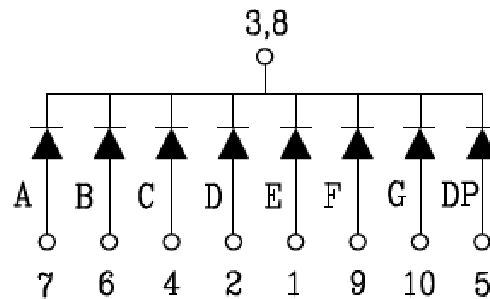



KASHINOKI SOGYO CO., LTD

製品名

文字高14.2mm赤セグメント5165Rカソードコモン

ABSOLUTE MAXIMUM RATINGS AT TA=25°C

PARAMETER	VALUE	UNITS
Power Dissipation Per Segment	75	mW
Peak Forward Current Per Segment (1/10 Duty Cycle, 0.1ms Pulse Width)	80	mA
Continuous Forward Current Per Segment	20	mA
Recommend Operating Current	12	mA
Reverse Voltage Per Segment	5	V
Operating Temperature Range	-25 to +85	°C
Storage Temperature Range	-30 to +85	°C
Junction Temperature	+85	°C
Storage Time at 25±2°C / 65%RH±5%RH	6	Month
Lead Solder Temperature(1/16 Inch Below Seating Plane)	260°C for 3 sec.	

ELECTRICAL/OPTICAL CHARACTERISTICS AT TA=25°C

PARAMETER	SYMBOL	MIN.	TYP.	MAX.	UNITS	TEST CONDITION	GRADE
Luminous Intensity Per Segment	I _V	4726	5435	6144	μcd	I _F =10mA	K
Luminous Intensity Per Segment	I _V	6145	7066	7987	μcd	I _F =10mA	M
Luminous Intensity Per Segment	I _V	7988	9185	10383	μcd	I _F =10mA	N
Peak Emission Wavelength	λ _P		660		nm	I _F =20mA	
Spectral Line Half-Width	Δλ		20		nm	I _F =20mA	
Forward Voltage Per Segment	V _F	1.7	1.8	2.0	V	I _F =20mA	
Reverse Current Per Segment	I _R			20	μA	V _R =5V	
Luminous Intensity Matching Rate	I _V -m			1.5:1		I _F =20mA	

Notes: Above specification may be changed without notice.