



KASHINOKI SOGYO CO., LTD

製品名

文字高101mm赤セグメント40101Rカソードコモン

APPEARANCE			TECHNOLOGIE	GaAlAs/GaAs
FACE	SEGMENT	PIN	SOURCE COLOR	Hi-red
Black	White	φ0.80x12.80	DRIVER MODE	Com.Cathode
			PACKING	Styrene Foam

PACKAGE DIMENSIONS

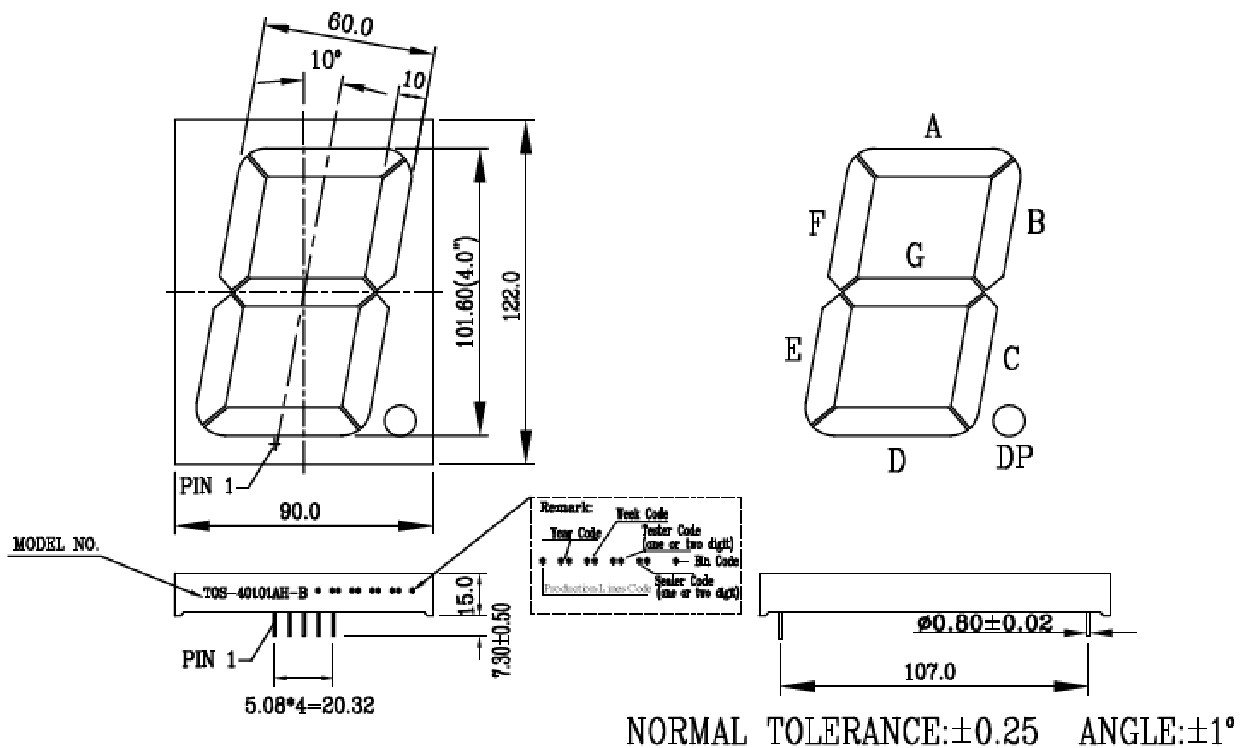

INTERNAL CIRCUIT DIAGRAM

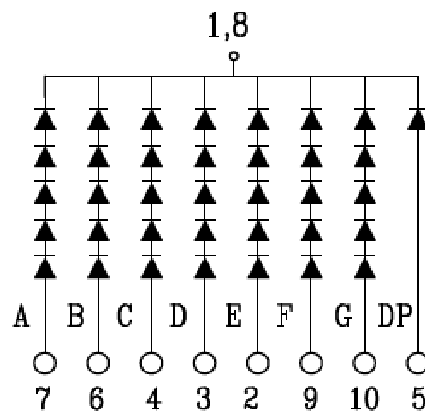



KASHINOKI SOGYO CO., LTD

製品名

文字高101mm赤セグメント40101Rカソードコモン

ABSOLUTE MAXIMUM RATINGS AT TA=25°C

PARAMETER	VALUE	UNITS
Power Dissipation Per Segment (Except Dp)	260	mW
Peak Forward Current Per Segment (1/10 Duty Cycle, 0.1ms Pulse Width)	80	mA
Continuous Forward Current Per Segment	20	mA
Recommend Operating Current	12	mA
Reverse Voltage Per Segment (Except Dp)	25	V
Operating Temperature Range	-25 to +85	°C
Storage Temperature Range	-30 to +85	°C
Junction Temperature	+85	°C
Storage Time at 25±2°C / 65%RH±5%RH	6	Month
Lead Sold Temperature(1/16 Inch Below Seating Plane)	260°C for 3 sec.	

ELECTRICAL/OPTICAL CHARACTERISTICS AT TA=25°C

PARAMETER	SYMBOL	MIN.	TYP.	MAX.	UNITS	TEST CONDITION	GRADE
Luminous Intensity Per Segment	I _v	2501	3000	3500	μcd	I _F =10mA	G
Luminous Intensity Per Segment	I _v	3501	4113	4725	μcd	I _F =10mA	H
Luminous Intensity Per Segment	I _v	4726	5435	6144	μcd	I _F =10mA	K
Peak Emission Wavelength	λ _P		660		nm	I _F =20mA	
Spectral Line Half-Width	Δλ		20		nm	I _F =20mA	
Forward Voltage Per Segment (Except Dp)	V _F	8.5	9	10	V	I _F =20mA	
Reverse Current Per Segment(Except DP)	I _R			20	μA	V _R =25V	
Luminous Intensity Matching Rate	I _v -m			1.5:1		I _F =20mA	

Notes: Above specification may be changed without notice.