



KASHINOKI SOGYO CO., LTD

製品名

文字高9.9mm赤セグメント3191R カソードコモン

APPEARANCE			TECHNOLOGIE	GaAlAs/GaAs
FACE	SEGMENT	PIN	SOURCE COLOR	Super-red
Black	White	φ0.45*10.28	DRIVER MODE	Com. Cathode
			PACKING	"XL" Plastic Box

PACKAGE DIMENSIONS

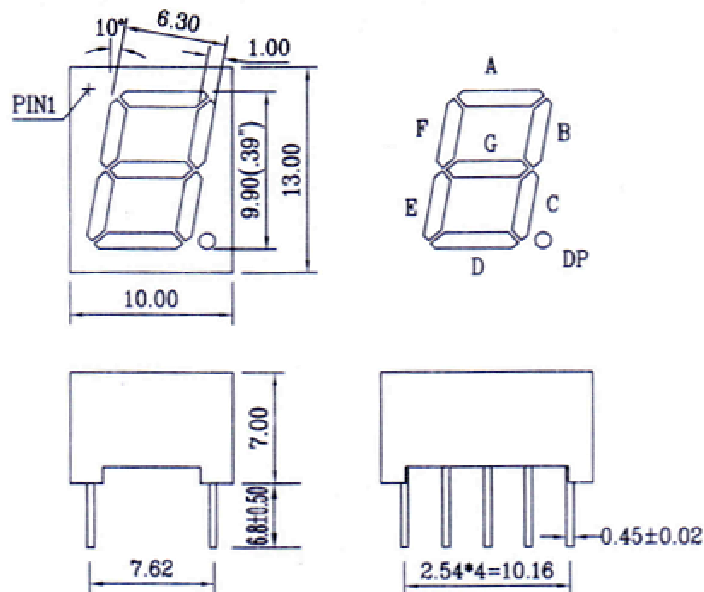

INTERNAL CIRCUIT DIAGRAM

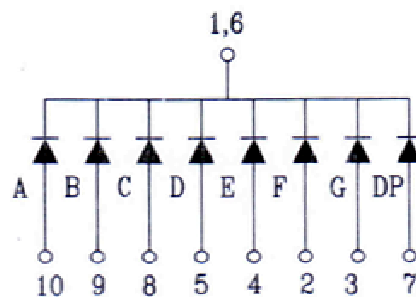



KASHINOKI SOGYO CO., LTD

製品名

文字高9.9mm赤セグメント3191R カソードコモン

ABSOLUTE MAXIMUM RATINGS AT TA=25°C

PARAMETER	VALUE	UNITS
Power Dissipation Per Segment	75	mW
Peak Forward Current Per Segment (1/10 Duty Cycle, 0.1ms Pulse Width)	80	mA
Continuous Forward Current Per Segment	20	mA
Recommend Operating Current	12	mA
Reverse Voltage Per Segment	5	V
Operating Temperature Range	-25 to +85	°C
Storage Temperature Range	-30 to +85	°C
Junction Temperature	+85	°C
Lead Solder Temperature(1/10 Inch Below Seating Plane)	260°C for 3 sec.	

ELECTRICAL/OPTICAL CHARACTERISTICS AT TA=25°C

PARAMETER	SYMBOL	MIN.	TYP.	MAX.	UNITS	TEST CONDITION	GRADE
Luminous Intensity Per Segment	I _v	7988	9185	10383	μcd	I _F = 10mA	N
Luminous Intensity Per Segment	I _v	10384	11941	13499	μcd	I _F = 10mA	P
Luminous Intensity Per Segment	I _v	13500	15524	17549	μcd	I _F = 10mA	R
Peak Emission Wavelength	λ _P		660		nm	I _F = 20mA	
Spectral Line Half-Width	Δλ		20		nm	I _F = 20mA	
Forward Voltage Per Segment	V _F	1.7	1.8	2.0	V	I _F = 20mA	
Reverse Current Per Segment	I _R			20	μA	V _R = 5V	
Luminous Intensity Matching Rate	I _v -m			1.5:1		I _F = 20mA	