



KASHINOKI SOGYO CO., LTD

製品名

文字高9.9mm青セグメント 3191B カソードコモン

APPEARANCE			TECHNOLOGIE	InGaN/SiC
FACE	SEGMENT	FLAT PIN	SOURCE COLOR	Blue
Black	White	0.30x10.28	DRIVER MODE	Com.Cathode
			PACKING	Tube(CR001)

PACKAGE DIMENSIONS

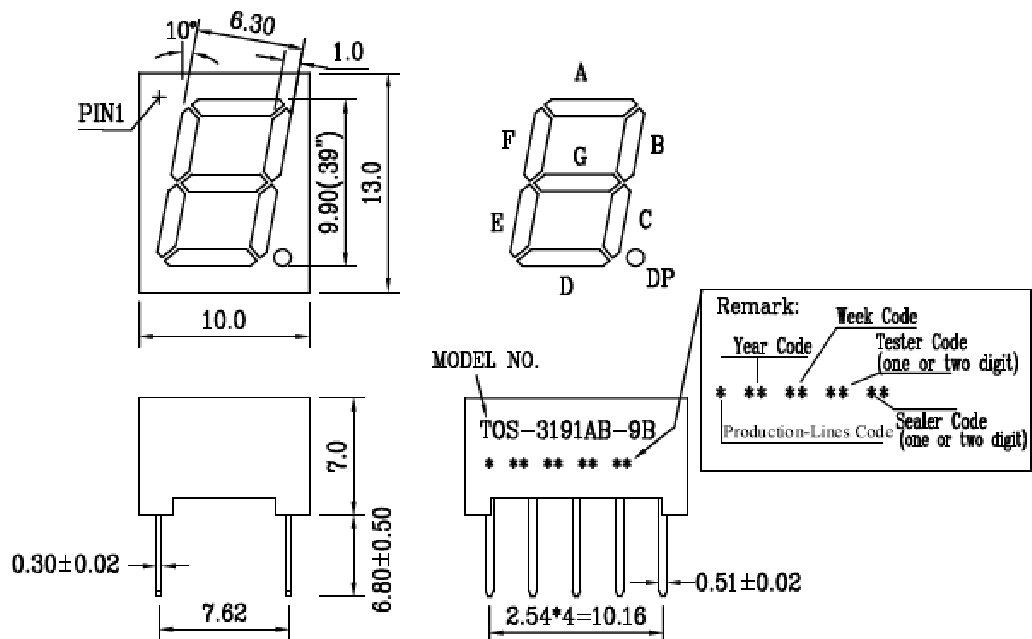

NORMAL TOLERANCE: ±0.25 ANGLE: ±1°

INTERNAL CIRCUIT DIAGRAM

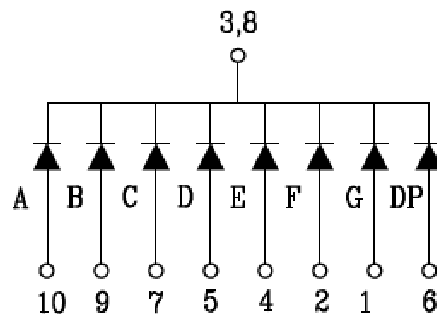



# KASHINOKI SOGYO CO., LTD

製品名

文字高9.9mm青セグメント 3191B カソードコモン

## ABSOLUTE MAXIMUM RATINGS AT TA=25°C

PARAMETER	VALUE	UNITS
Power Dissipation Per Segment	105	mW
Peak Forward Current Per Segment (1/10 Duty Cycle, 0.1ms Pulse Width)	80	mA
Continuous Forward Current Per Segment	20	mA
Recommend Operating Segment	12	mA
Reverse Voltage Per Segment	5	V
Operating Temperature Range	-25 to +85	°C
Storage Temperature Range	-30 to +85	°C
Junction Temperature	+85	°C
Storage Time at 25±2°C / 65%RH±5%RH	6	Month
Lead Sold Temperature(1/16 Inch Below Seating Plane)	260°C for 3 sec.	

## ELECTRICAL/OPTICAL CHARACTERISTICS AT TA=25°C

PARAMETER	SYMBOL	MIN.	TYP.	MAX.	UNITS	TEST CONDITION
Luminous Intensity Per Segment	I <sub>v</sub>		21937		μcd	I <sub>F</sub> = 10mA
Dominant Emission Wavelength	λ <sub>d</sub>		460		nm	I <sub>F</sub> = 20mA
Spectral Line Half-Width	Δλ		26		nm	I <sub>F</sub> = 20mA
Forward Voltage Per Segment	V <sub>F</sub>		3.5	4.0	V	I <sub>F</sub> = 20mA
Reverse Current Per Segment	I <sub>R</sub>			50	μA	V <sub>R</sub> = 5V
Luminous Intensity Matching Rate	I <sub>v</sub> -m			2.0:1		I <sub>F</sub> = 20mA

Notes: Above specification may be changed without notice.