



KASHINOKI SOGYO CO., LTD

製品名

文字高57mm青セグメント23101Bカソードコモン

APPEARANCE			TECHNOLOGIE	InGaN/SiC
FACE	SEGMENT	PIN	SOURCE COLOR	Blue
Gray	White	φ0.60x10.28	DRIVER MODE	Com.Cathode
			PACKING	Tube(23101)

PACKAGE DIMENSIONS

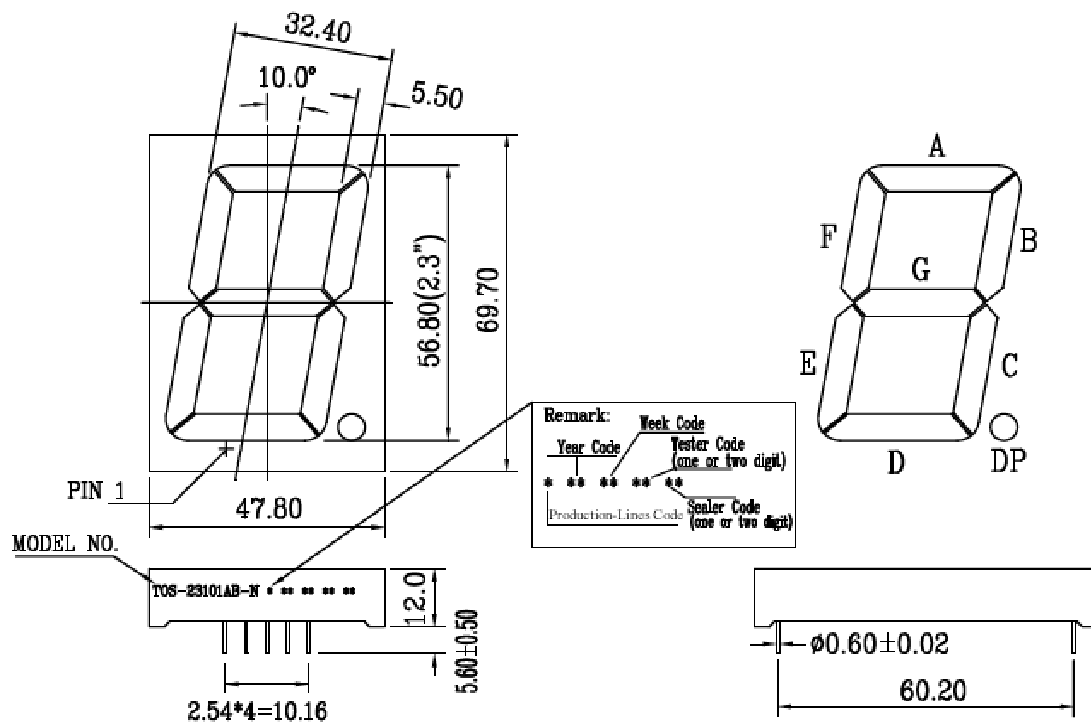

NORMAL TOLERANCE:±0.25 ANGLE:±1°

INTERNAL CIRCUIT DIAGRAM

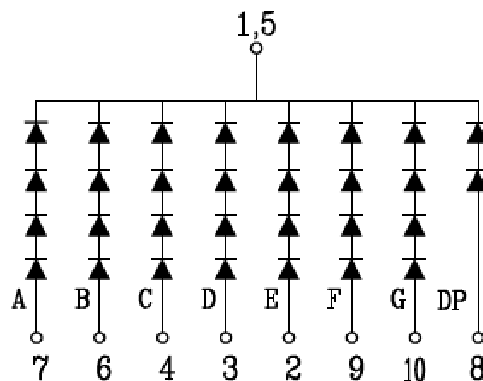



KASHINOKI SOGYO CO., LTD

製品名

文字高57mm青セグメント23101Bカソードコモン

ABSOLUTE MAXIMUM RATINGS AT TA=25°C

PARAMETER	VALUE	UNITS
Power Dissipation Per Segment (Except Dp)	420	mW
Peak Forward Current Per Segment (1/10 Duty Cycle, 0.1ms Pulse Width)	80	mA
Continuous Forward Current Per Segment	20	mA
Recommend Operating Current	12	mA
Reverse Voltage Per Segment (Except DP)	20	V
Operating Temperature Range	-25 to +85	°C
Storage Temperature Range	-30 to +85	°C
Storage Time at 25±2°C/65%RH±5%RH	6	Month
Junction Temperature	+85	°C
Lead Solder Temperature(1/16 Inch Below Seating Plane)	260°C for 3 sec.	

ELECTRICAL/OPTICAL CHARACTERISTICS AT TA=25°C

PARAMETER	SYMBOL	MIN.	TYP.	MAX.	UNITS	TEST CONDITION
Luminous Intensity Per Segment	I _v		32907		μcd	I _F = 10mA
Dominant Emission Wavelength	λ _d		460		nm	I _F = 20mA
Spectral Line Half-Width	Δλ		26		nm	I _F = 20mA
Forward Voltage Per Segment (Except Dp)	V _F		14.0	16.0	V	I _F = 20mA
Reverse Current Per Segment (Except Dp)	I _R			50	μA	V _R = 20V
Luminous Intensity Matching Rate	I _v -m			2.0:1		I _F = 20mA