



KASHINOKI SOGYO CO., LTD

製品名

セグメント(コモン:カソード) 品名:文字高38mm15102G(緑)

APPEARANCE			TECHNOLOGIE	AlGaInP/GaAs
FACE	SEGMENT	PIN	SOURCE COLOR	Ultra-Green
Gray	White	φ0.51x12.8	DRIVER MODE	Com. Cathode
			PACKING	Tube(15102)

PACKAGE DIMENSIONS

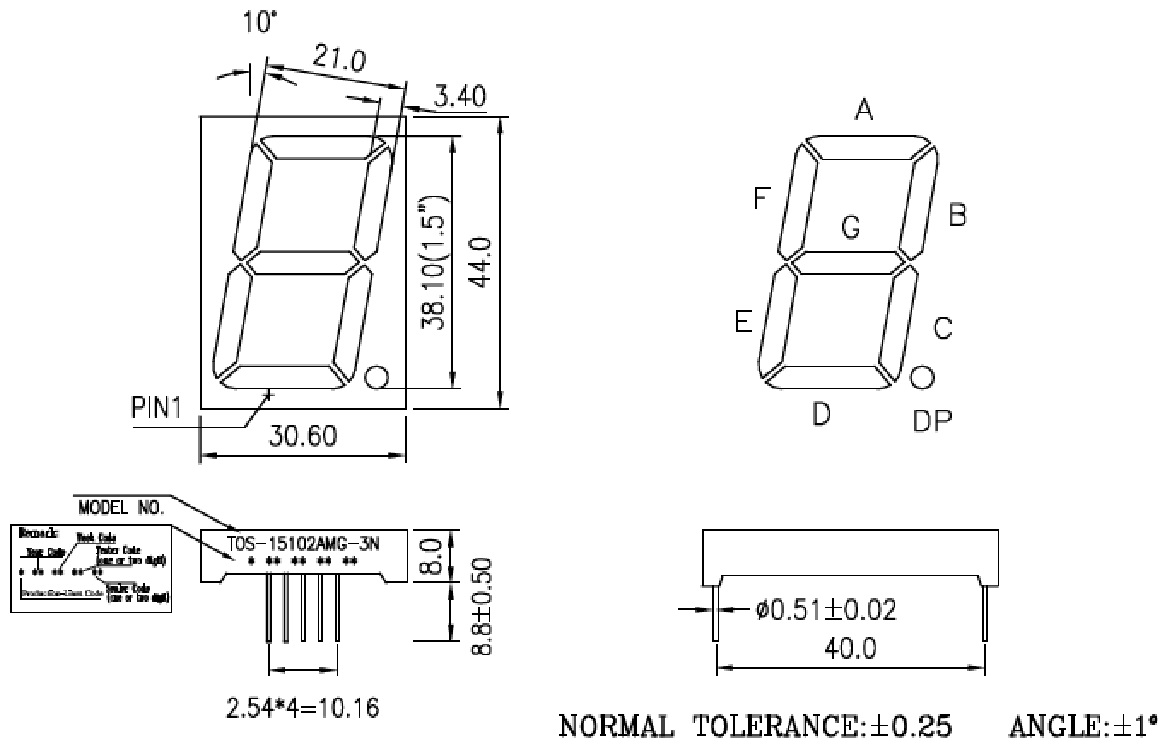

INTERNAL CIRCUIT DIAGRAM

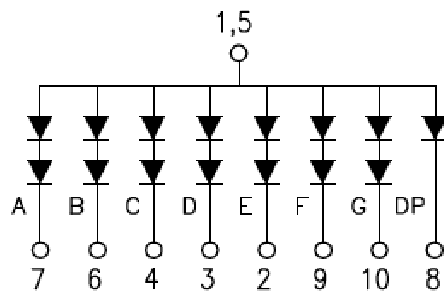



KASHINOKI SOGYO CO., LTD

製品名

セグメント(コモン:カソード 品名:文字高38mm15102G(緑))

ABSOLUTE MAXIMUM RATINGS AT TA=25°C

PARAMETER	VALUE	UNITS
Power Dissipation Per Segment (Except DP)	140	mW
Peak Forward Current Per Segment (1/10 Duty Cycle, 0.1ms Pulse Width)	80	mA
Continuous Forward Current Per Segment	20	mA
Recommend Operating Current	12	mA
Reverse Voltage Per Segment (Except DP)	10	V
Operating Temperature Range	-25 to +85	°C
Storage Temperature Range	-30 to +85	°C
Junction Temperature	>85	°C
Lead-Free Solder Temperature(1/16 Inch Below Seating Plane)	260°C for 3 sec.	

ELECTRICAL/OPTICAL CHARACTERISTICS AT TA=25°C

PARAMETER	SYMBOL	MIN.	TYP.	MAX.	UNITS	TEST CONDITION
Luminous Intensity Per Segment	I _v		15524		μcd	I _F =10mA
Dominant Emission Wavelength	λ _d		572		nm	I _F =20mA
Spectral Line Half-Width	Δλ		15		nm	I _F =20mA
Forward Voltage Per Segment (Except DP)	V _F	3.6	4.0	4.6	V	I _F =20mA
Reverse Current Per Segment (Except DP)	I _R			100	μA	V _R =10V
Luminous Intensity Matching Rate	I _v -m			2.0:1		I _F =20mA

Notes:Above specification may be changed without notice.