



# KASHINOKI SOGYO CO.,LTD

製品名

文字高25.4mm青セグメント1107Bアノードコモン

APPEARANCE			TECHNOLOGY	InGaN/SiC
FACE	SEGMENT	PIN	SOURCE COLOR	Blue
Gray	White	φ0.51x10.28	DRIVER MODE	Com. Anode
			PACKING	"F"Plastic Box

## PACKAGE DIMENSIONS

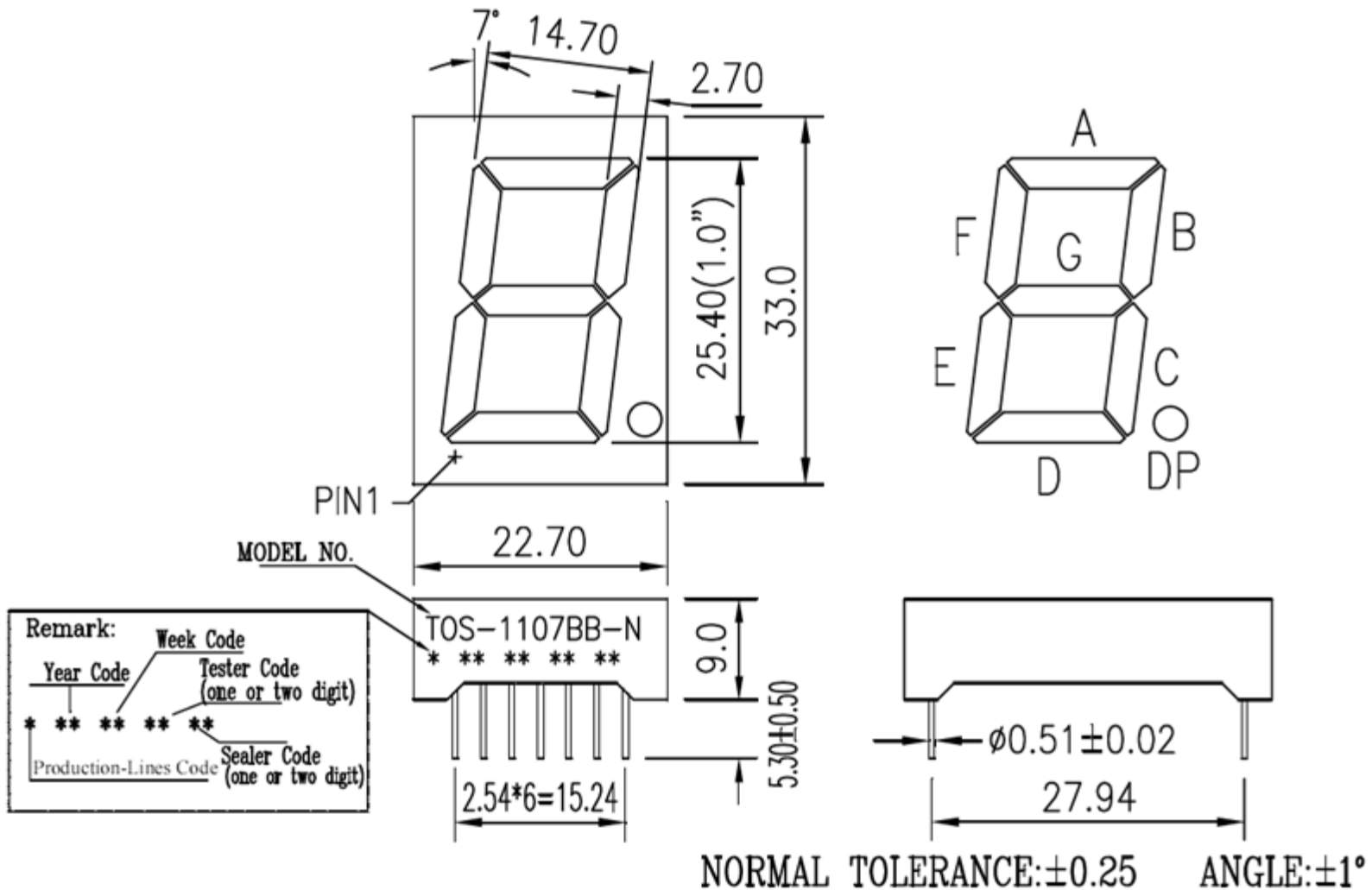

## INTERNAL CIRCUIT DIAGRAM

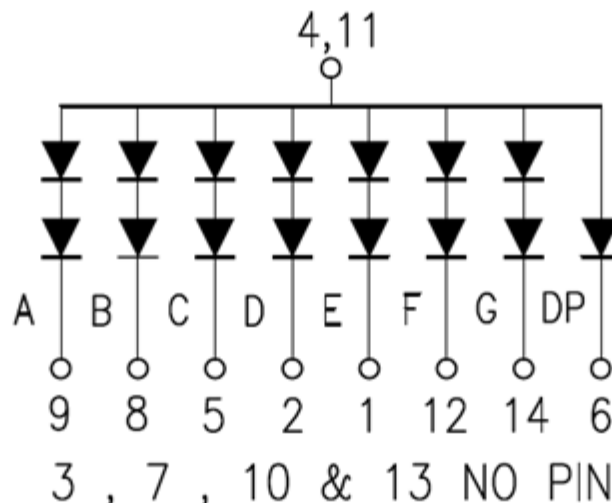



# KASHINOKI SOGYO CO.,LTD

製品名

文字高25.4mm青セグメント1107Bアノードコモン

## ABSOLUTE MAXIMUM RATINGS AT TA=25°C

PARAMETER	VALUE	UNITS
Power Dissipation Per Segment (Except Dp)	210	mW
Peak Forward Current Per Segment (1/10 Duty Cycle, 0.1ms Pulse Width)	80	mA
Continuous Forward Current Per Segment	20	mA
Recommend Operating Current	12	mA
Reverse Voltage Per Segment (Except Dp)	10	V
Operating Temperature Range	-25 to +85	°C
Storage Temperature Range	-30 to +85	°C
Junction Temperature	+85	°C
Storage Time at 25±2°C / 65%RH±5%RH	6	Month
Lead Solder Temperature(1/16 Inch Below Seating Plane)	260°C for 3 sec.	

## ELECTRICAL/OPTICAL CHARACTERISTICS AT TA=25°C

PARAMETER	SYMBOL	MIN.	TYP.	MAX.	UNITS	TEST CONDITION
Luminous Intensity Per Segment	I <sub>v</sub>		32907		μcd	I <sub>F</sub> =10mA
Dominant Emission Wavelength	λ <sub>d</sub>		460		nm	I <sub>F</sub> =20mA
Spectral Line Half-Width	Δλ		26		nm	I <sub>F</sub> =20mA
Forward Voltage Per Segment (Except DP)	V <sub>F</sub>		7.0	8.0	V	I <sub>F</sub> =20mA
Reverse Current Per Segment	I <sub>R</sub>			50	μA	V <sub>R</sub> =10V
Luminous Intensity Matching Rate	I <sub>v</sub> -m			2.0:1		I <sub>F</sub> =20mA

Notes: Above specification may be changed without notice.